

POLICY & PROCEDURE MANUAL

SECTION	TRANSPORTATION SERVICES	POLICY NUMBER	5-3-17
SUB-SECTION	ADMINISTRATION	EFFECTIVE	June 14, 2012
SUBJECT	Entrance Policy		
AUTHORITY	Public Works Committee – May 23, 2012 Council – June 14, 2012		

PURPOSE:

To define the Public Works Department's policies and procedure on the control, installation, classification, reclassification, replacement and standards of accesses to County roads so that:

- the safety of the travelling public is ensured,
- the operating integrity of the road system is protected by ensuring the efficient flow of traffic,
- the impact of development on the road system is minimized,
- future maintenance and reconstruction costs are minimized or reduced.

STATEMENT:

1. Control of Entrances

All entrances onto County roads shall be under the control of the Dufferin County Public Work Department. New installations shall conform to this policy and be completed according to standards. The costs shall be borne by the owners.

2. Entrance Permits Are Required For:

- construction of a new entrance
- changing the design of an existing entrance
- changing the location of an existing entrance
- changing the use of an existing entrance (i.e.) the classification
- construction of a temporary entrance
- paving of an existing entrance

SUBJECT	Entrance Policy	POLICY NUMBER	5-3-17
----------------	-----------------	----------------------	--------

3. Inventory of Entrances

The Dufferin Public Work Department shall maintain an inventory of all entrances onto County roads. The inventory shall contain the classification and details of each entrance.

4. Classification of Entrances

All entrances shall be classed into one of the following classes. The classification of an entrance cannot change, nor the entrance be used for any other purpose, without the entrance being reclassified by obtaining an entrance permit through the application process.

Field Entrance

- provides access to agricultural fields.

Farm Entrance

- provides access to farm buildings and agricultural fields. Where a farm entrance also provides access to a farm residence it shall be classified as a residential entrance.

Residential Entrance

- provides access to residential facilities of four units or less.

Commercial/Industrial/Institutional Entrance

- provides access to a business where goods or services are manufactured, sold or distributed.

Temporary Entrance

- provides access to properties for a limited period of time, not to exceed one year, for the purpose of construction, repairs, or improvements on that property or to facilitate staged development. If an extension is required, the owner must apply for a new permit prior to the expiration of the existing one.

A temporary permit shall specify:

- the expiry date
- the extent and nature of the works to be done on the property
- the owner's responsibility to clean up mud or debris from the road in a timely fashion.

Emergency Entrance

- provides access to subdivision developments for emergency vehicles only, in the event that the main entrance to the development is not passable. Adequate measures are to be incorporated to prevent use by residents or for delivery vehicles.

Public Entrance

- provides access onto a County road from a registered subdivision by means of a public street.

SUBJECT	Entrance Policy	POLICY NUMBER	5-3-17
----------------	-----------------	----------------------	--------

Private Road

Private roads provide access to the following:

- access to residential units of five or more units
- into townhouse condominium developments
- roads into public facilities such as landfill sites, parks, public institutions etc.
- private roads into resort areas providing access to a number of lots

5. General Policies

a. Number of Entrances per Lot of Record

The following numbers of entrances per property shall be restricted to:

Field Entrances

- a minimum of one per farm with additional field entrances where natural obstructions within the field prevent reasonable access across the field.

Farm

- one per farm for farm buildings

Residential

- one per property

Commercial/Industrial/Institutional

- maximum of two with a minimum spacing of 30 metres between entrances

b. Alternative Access

Access shall be gained from a Town, Village or Township right-of-way where it can reasonably be achieved.

c. Existing Lots of Record

Each lot which is legally in existence is entitled to a residential entrance onto a County Road, if no alternative access exists.

d. Infilling

Infilling refers to the development of vacant lots with existing buildings on both sides in urban areas where the pattern of development and the building line are already established. Extension of an existing built up area is not considered infilling.

Infilling will be permitted due to the minimal effect on the operation of the road. Reduced setbacks shall be considered if they are in line with existing development.

SUBJECT	Entrance Policy	POLICY NUMBER	5-3-17
----------------	-----------------	----------------------	--------

e. Service Roads

In order to provide access to lots adjacent to a County road, a service road may be built parallel and adjacent to the County road. It shall be under local jurisdiction or privately owned. Setbacks shall be calculated from the service road property line.

6. Policies Related to Safety

a. Minimum Visibility Requirements

Sight distances are measured from a point 3 metres from the outer edge of the traffic lane at an eye level of 1.05 metres above the edge of the traffic lane to an object 0.60 metres in height above the roadway surface in the centre of all lanes affected by the entering vehicle. For example, on a two (2) lane road the distance is measured to the centre of the lanes in both directions. A sight distance verification report and plan prepared by an Ontario Land Surveyor may be requested by the County.

(i) Field, Farm, Residential and Temporary Entrances

New entrances, for field, farm, residential and temporary entrances must meet the following minimum sight distances.

Posted Speed (km/hr)	Minimum Sight Distance (metres)
40	125
50	135
60	165
70	180
80	200
90	220
100	240

(ii) Commercial Entrances

All new commercial entrances must meet all of the following minimum requirements:

Speed Limit (km/hr)	Sight Distance (metres)	Horizontal Curve (metres)	Grade (%)
40	140	300	6
50	160	300	6
60	180	600	5
70	200	600	5
80	230	1,200	4
90	250	1,200	4
100	270	1,200	4

Notes:

- In urban areas where the speed limit is significantly lower than the design speed the sight distance may be reduced.

SUBJECT	Entrance Policy	POLICY NUMBER	5-3-17
----------------	-----------------	----------------------	--------

- Commercial entrances must be constructed and approved before the establishment is open for business.

b. Minimum Visibility Requirements at Structures

The minimum sight distance requirements of entrances adjacent to bridges shall be applied.

c. Requirements for Visibility Triangles at Intersections

Visibility triangles are defined by (X), the distance measured along the property line on the County road and (Y), the distance measured along the property line on the side road (i.e.) these distances are measured from the intersection of the two right-of-way lines.

Posted Speed (km/hr)	Visibility Triangle X & Y County Road Right of Way					
	20 metre		30 metre		45 metre	
	X	Y	X	Y	X	Y
40	8	7	2	2	-	-
50	15	10	7	5	-	-
60	22	11	12	6	-	-
70	29	12	17	7	-	-
80	32	12	19	7	-	-
90	29	14	24	8	2	1

d. Requirements for Spacing from Side Road Intersections

Entrances onto the sight line of the visibility triangle are not permitted. The following table is based on a right-of-way of 30 metres and gives the minimum distances from the centreline of the intersecting road to the closest side of the proposed entrance. The requirements for other widths of right-of-ways will be provided.

Posted Speed (km/hr)	Distance on County Road (metres)	Distance on side road (metres)
40	40	25
40	50	25
50	60	25
60	65	25
70	75	25
80	85	25
90	95	25

SUBJECT	Entrance Policy	POLICY NUMBER	5-3-17
----------------	-----------------	----------------------	--------

7. Policies Related to Road Operation

a. Density of Entrances

Density of entrances refers to the number of entrances over a distance. Original lot lines and original half lot lines are used to define the distance and where the distance begins and ends. For example, where a road runs perpendicular to the original lot lines, the distance is defined by the original lot lines and where a road runs parallel, or nearly parallel to the original lot lines, the distance is defined by the original half lot lines at the half concession point and the road allowance between concessions.

New entrances for all county roads will only be permitted where the density spacing of driveway entrances on one side of the road meets the criteria in the following table:

Road Number	Maximum Number of Entrances per Original Lot or per Original Half Lot
County Roads 18 and 109	3
All Other County Roads	4

b. Spacing and Frontage Requirements

Spacing of side roads for the various classifications of roads must meet the criteria in the follow table:

Classification of Road	Minimum Public Road Intersection Spacing
County Roads 18 and 109	460 metres
County Roads <80 km/hr.	300 metres
All other County Roads	365 metres

c. Location of Intersections

Where intersections occur, they shall be located opposite each other to line up with an entrance on the other side of the road.

d. Truck Climbing Lanes, Deceleration Lanes and Acceleration Lanes

No access will be permitted on truck climbing, acceleration or deceleration lanes.

e. Guide Rails

No access will be permitted which require crossing through existing guide rails, guide posts, steel beam guide rail or 3 cable guide cable.

SUBJECT	Entrance Policy	POLICY NUMBER	5-3-17
----------------	-----------------	----------------------	--------

ENTRANCE STANDARDS:

1. Location of Entrances

The County may restrict the placement of an access onto a County road in the interest of public safety. New entrances must be located, in the opinion of the County Engineer, so that there are favourable vision, grade and alignment conditions for all traffic using the proposed entrance and the County road.

Minimum entrance distances from side property line to centreline of entrance

- Private, Field and Residential Entrance – 9 metres
- Farm Entrance – 14 metres
- Commercial, Industrial, Institutional Entrance – 20 metres

2. Commercial/Industrial/Institutional Entrances and Public and Private Roads

Designs for commercial/industrial/institutional entrances and public and private roads must be submitted for approval as part of the entrance permit application procedure. The design shall be site specific, having regard for the number and type of vehicles expected to utilize the entrance. The entrance must be constructed and approved (including paving where required by this policy) before the establishment or the public or private road is open for business or use. The design shall provide for the entrance to be surfaced with asphalt to the property line.

3. Entrance Grades

The finish grade of the entrance must drop away from the edge of the driving lane surface to the edge of the shoulder at the same rate as the shoulder. For a distance of 5.0 metres beyond the edge of the shoulder the slope shall not exceed 3%.

For entrances on a steep slope or where earth cut or fill is required, Grading Plans showing existing and proposed features along with existing and proposed elevations will be required and to be submitted to the County for approvals.

4. Field Entrances

Field entrances must be surfaced with at least 150 mm (6") of pit run or granular B. Where a culvert is required, its length shall be sufficient to provide a 2:1 slope up from the ditch invert to an entrance width of 6.0 metres. A minimum cover on the culvert shall be 300 mm (12"). Refer to drawings DC-01 and DC-02.

5. Farm Entrances

Farm entrances must be surfaced with at least 150 mm (6") of pit run or granular A. Where a culvert is required, its length shall be sufficient to provide a 2:1 slope up from the ditch invert to an entrance width of 6.0 metres. A minimum cover on the culvert shall be 300 mm (12"). Refer to drawings DC-01 and DC-02.

SUBJECT	Entrance Policy	POLICY NUMBER	5-3-17
----------------	-----------------	----------------------	--------

6. Residential Entrances

Residential entrances must be surfaced with at least 150 mm (6") of pit run or granular A. Where a culvert is required, its length shall be sufficient to provide a 2:1 slope up from the ditch invert to an entrance width of 6.0 metres. A minimum cover on the culvert shall be 300 mm (12"). Refer to drawings DC-01 and DC-02.

7. Culvert

If a culvert is required, the culvert shall be a new Corrugated Steel Pipe (C.S.P.) or a new High Density Polyethylene Pipe (HDPE). Used culvert pipe is not acceptable. All pipes to be C.S.A. approved and installed as per manufacturer's specifications.

8. Surface Water

Each entrance shall be designed, installed and maintained in a manner that will prevent surface water runoff from the entrance or from the adjoining property from being discharged onto the travelled portion of the road or the shoulder of the road. Water shall be directed into the roadside ditches. Rip rap of entrance ditches may be necessary to prevent siltation of the roadside ditches.

9. Curb and Gutter

Where curb and gutter exists at the location of a proposed entrance, the applicant shall be required to construct a drop curb at the entrance location. The existing curb shall be cut or removed and replaced using materials and construction methods acceptable to the County.

The area behind the curb and sidewalk is to be paved with hot mix asphalt, concrete or paving stones, in accordance with the County's requirements to a distance of 2 metres behind the curb.

10. Temporary/Emergency Entrances

The design and construction details of temporary/emergency accesses must be submitted to, and approved by the County.

MAINTENANCE OF ENTRANCES

- a. If the surface of an approved entrance is gravel, the County will maintain the surface of an approved entrance from the edge of the travelled lane of the road to the outer edge of the shoulder.
- b. If the surface of an approved entrance is hard topped, the County will not maintain the surface.
- c. After the initial installation of the culvert any subsequent replacement or repair, (but not widening), shall be done by the County at its expense.
- d. Curbs and or headwalls will not be built, maintained or replaced by the County. No curb or headwall shall extend above the surface of the shoulder.

SUBJECT	Entrance Policy	POLICY NUMBER	5-3-17
----------------	-----------------	----------------------	--------

STANDARD DRAWINGS:

The following standard drawings shall apply:

- Drawing DC-01 Field, Farm and Residential Entrance on Earth Cut
- Drawing DC-02 Field, Farm and Residential Entrance on Earth Fill
- Drawing DC-03 Commercial, Industrial, Institutional Entrance on Earth Cut
- Drawing DC-04 Commercial, Industrial, Institutional Entrance on Earth Fill

PROCEDURES:

1. Requests for New or Reclassified Entrances

All requests for new installations, or reclassifications of existing entrances, shall be applied for by the property owner or an agent on forms supplied by the Road Department. The County shall determine the location, length and diameter of a culvert that is required and any conditions that must be met, financial or otherwise, prior to, or as part of the installation.

2. Application

The proposed entrance location shall be clearly illustrated on a sketch, which is to accompany the application. The sketch must provide enough information to enable staff to locate it in the field (i.e.) dimensions to buildings and/or landmarks such as fences hedgerows, tree lines etc. A non-refundable application fee shall be payable to the County of Dufferin with the application.

The application fees are identified in the County Fee Bylaw.

3. Entrance Permit

If approved, an Entrance Permit will be issued after a refundable deposit is made to the County. The cost for the permit shall be included in the application fee.

4. Change of Ownership of Property

Should the ownership of the property change after the date of the application, the new owner shall become the applicant.

5. Refundable Deposit

Refundable deposits in the amounts identified in the County Fee Bylaw, payable to the County of Dufferin, shall be collected prior to the County issuing a permit. The deposit will be refunded to the applicant upon acceptance of the installation by the County, less any amounts expended by the County to bring the entrance installation to County standards.

SUBJECT	Entrance Policy	POLICY NUMBER	5-3-17
----------------	-----------------	----------------------	--------

6. Installation of the Entrance

The entrance shall be installed by the applicant, at the applicant's expense, to the specifications outlined on the permit and in accordance with County standards.

7. Inspection of the Entrance

The installation of the entrance will be inspected by the County after completion by the applicant. It shall be the applicant's responsibility to call the County for an inspection of the entrance installation, once it has been completed.

8. Adjustments Required

Should any adjustments be required, they must be done within ten (10) days of notification by the County.

9. Cancellation of Permit

Where the entrance has not been constructed and accepted by the County within 6 months of the date of the permit, the permit shall be cancelled and the refundable deposit shall be forfeited.

10. Renewal of Permit

An entrance permit may be renewed for an additional six (6) month period. An application shall be filled out for the renewal and another application fee paid to the County. A second permit will be issued. The deposit fee shall be carried forward to the second permit.

11. Opinion of Entrance

An opinion on the availability of an entrance can be obtained by providing the necessary fee (no deposit) and application forms. This process is helpful during a severance application and can be provided by County staff. The County would not issue a permit, only given an opinion on the likelihood of success in obtaining an entrance permit.

When/if the applicant decides to proceed with the entrance permit application, the entrance application will be updated and the refundable portion collected. If the owner does not apply for the entrance permit within twelve months of the opinion, a new permit process will be required.

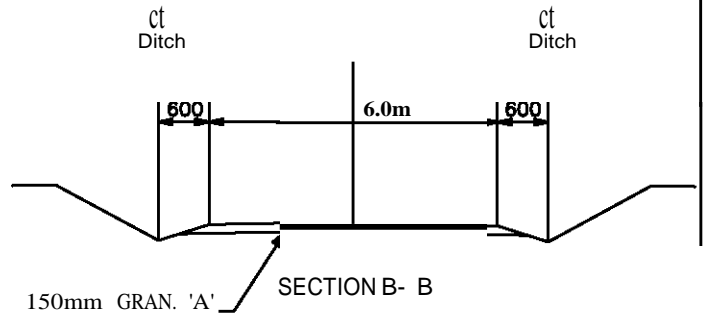
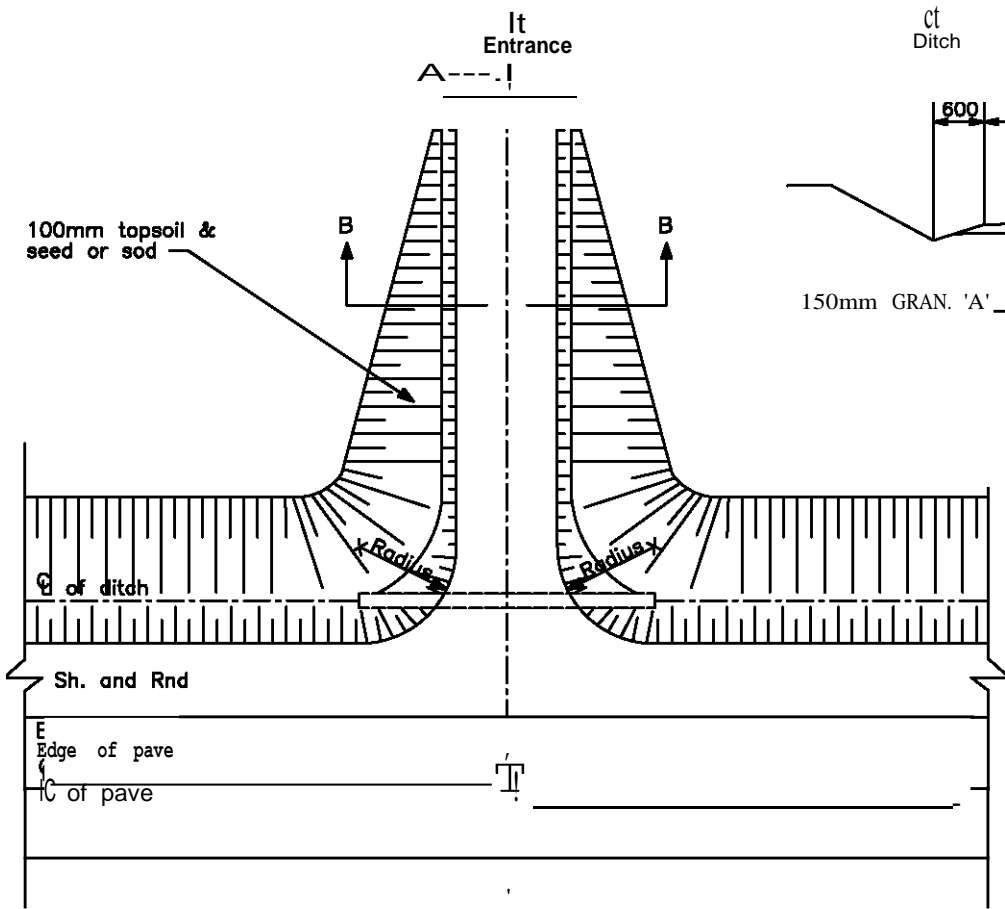

Entrance radii
 Private or field 5.0m
 Farm 10.0m

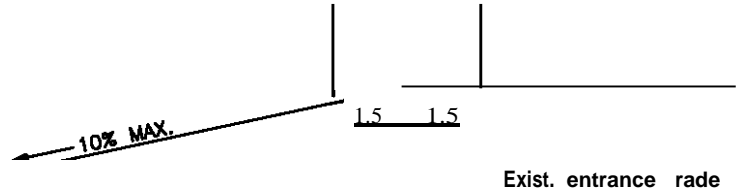
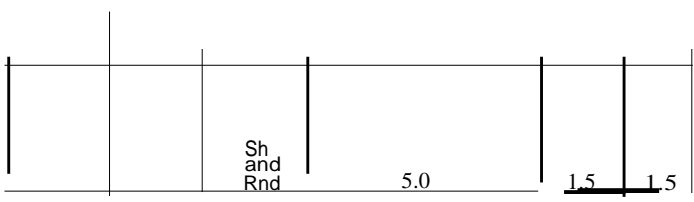

0.5" MIN-

SECTION A-A

Culvert
 Min. Dia. 450mm
 Min. cover 300mm
 Min. length 10m

EARTH CUT

NOTE: All dimensions are in meters
or millimeters unless otherwise
specified.

DUFF
ERIN
COUN
TY

**E
N
T
R
A
N
C
E**

RESIDENTIAL,

FARM OR FIELD

SEPTEMBER 1999

DC -01

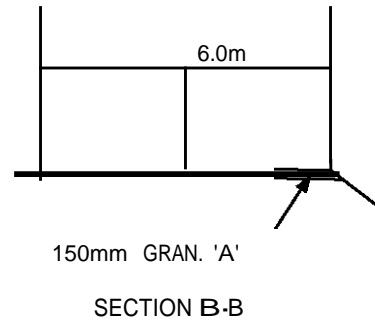
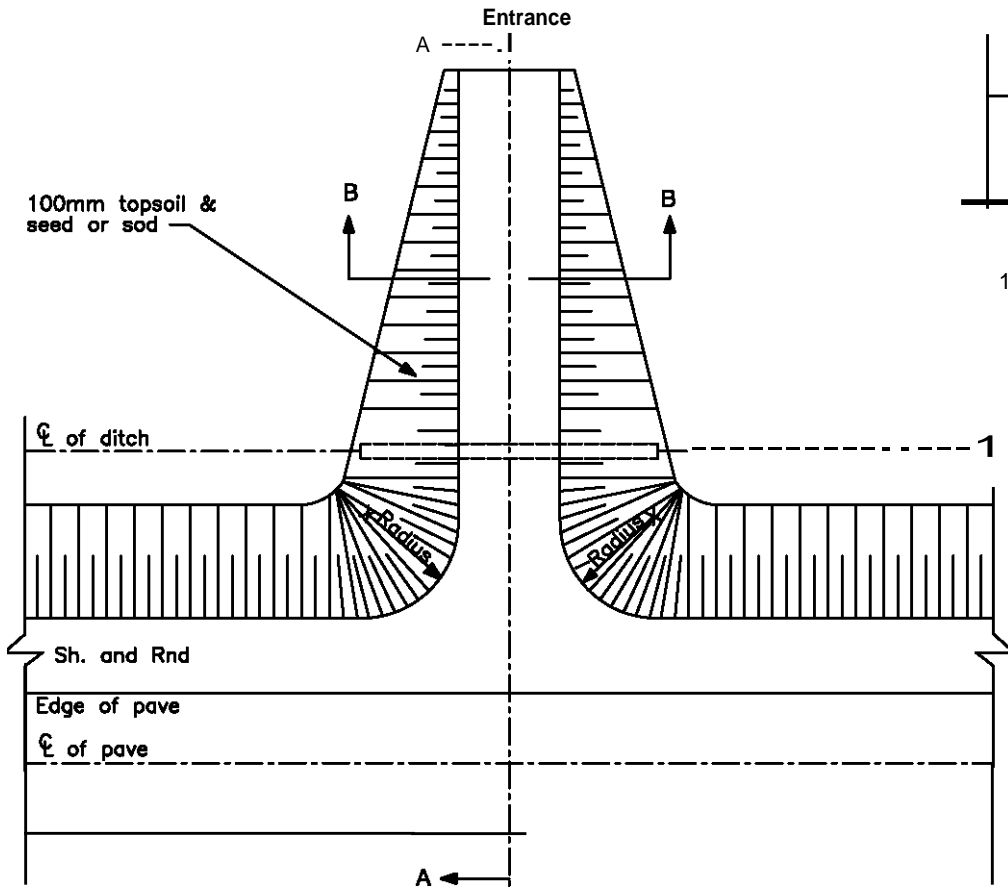

PLAN

Entrance radii
 Private or field 5.0m
 Farm 10.0m

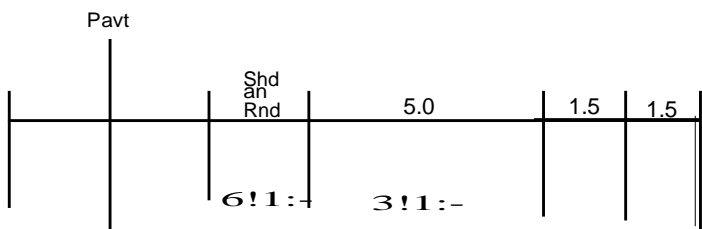

SECTION A - A

10l(MAx

m

Exist. entrance Qroda

Culvert
 Min. Dia. 450mm
 Min. cover 300mm
 Min. length 10m

EARTH FILL

NOTE: All dimensions are in meters or millimeters unless otherwise specified.

DUFFERIN COUNTY

ENTRANCE
 RESIDENTIAL, FARM OR FIELD

SEPTEMBER 1999

DC-02

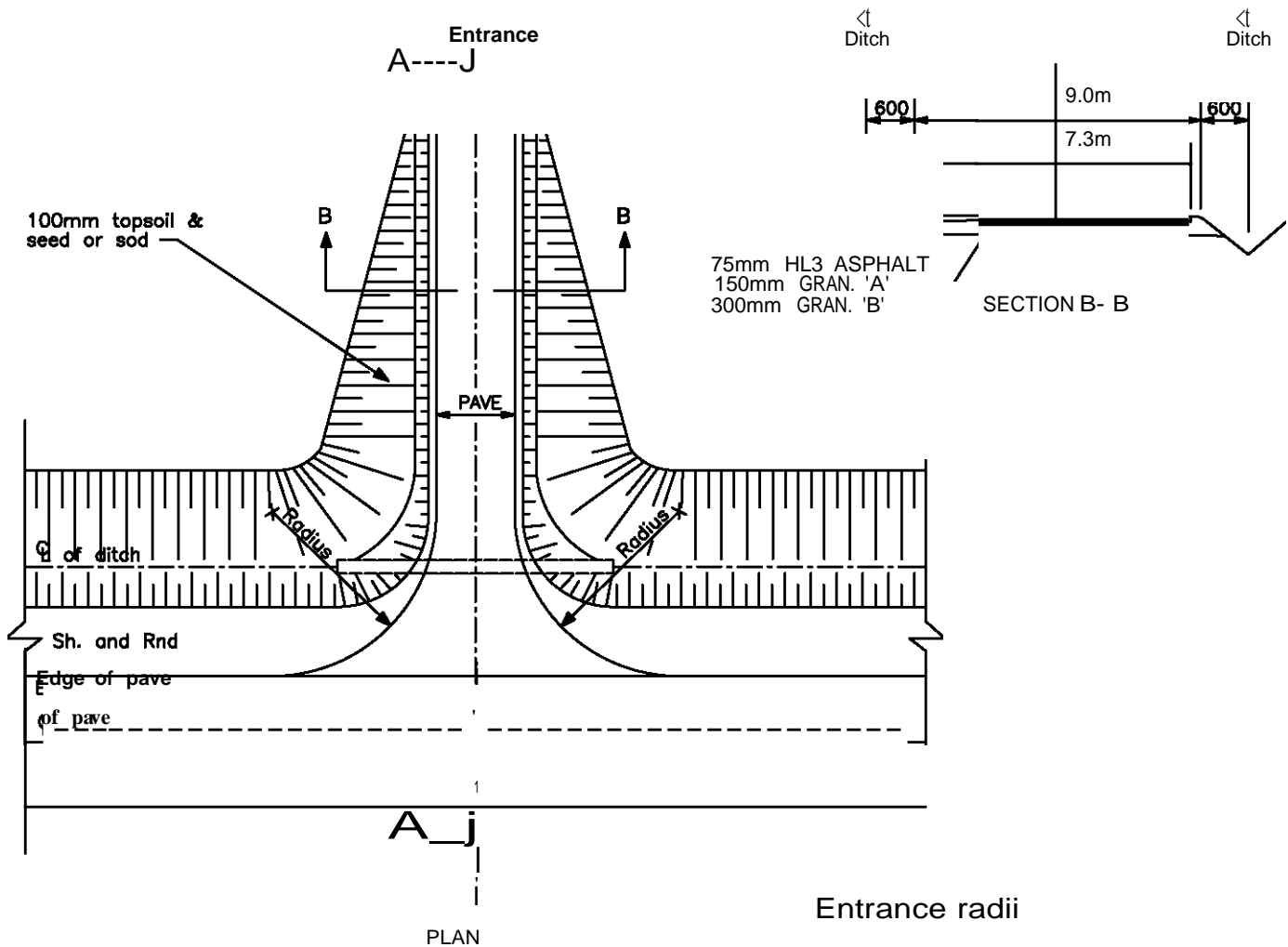

Entrance radii
Commercial - 15m

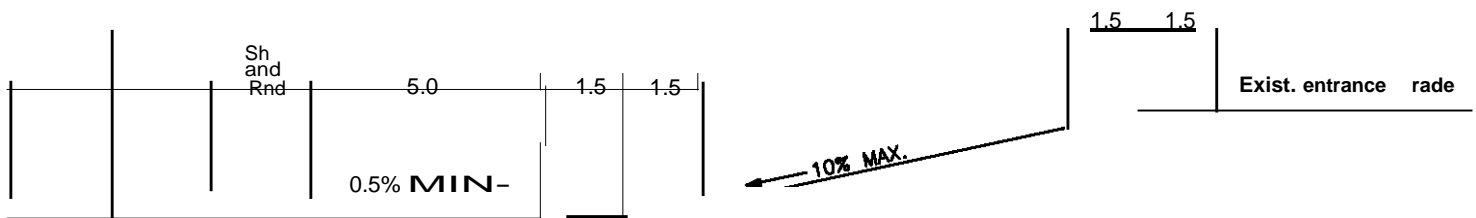

SECTION A-A

Culvert
Min. Dia. 450mm
Min. cover 300mm
Min. length 10m

EARTH CUT

NOTE: All dimensions are in meters or millimeters unless otherwise specified.

DUFFERIN COUNTY

ENTRANCE

COMMERCIAL INDUSTRIAL INSTITUTIONAL

SEPTEMBER 1999

DC-03

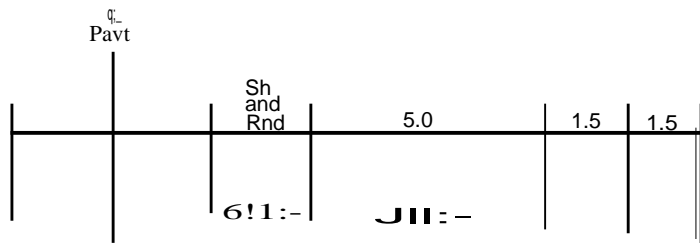
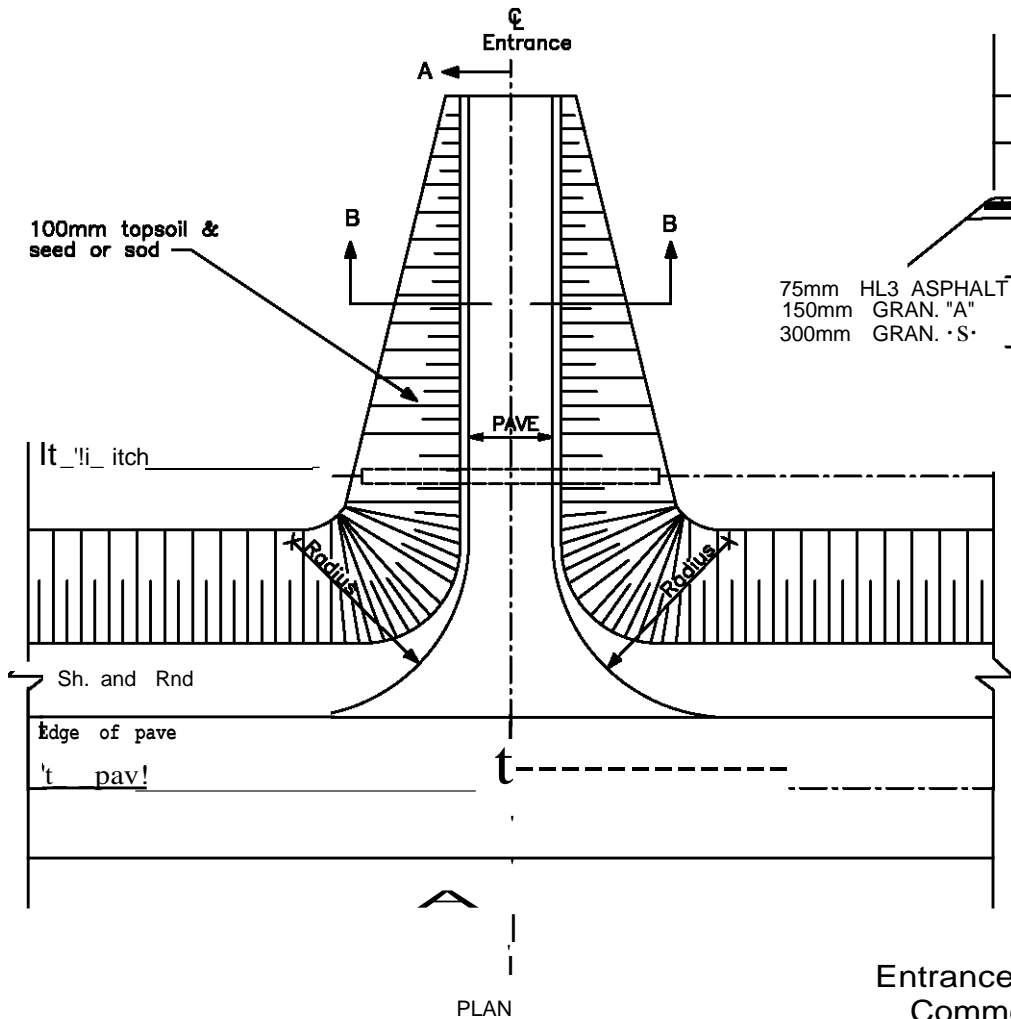

SECTION A - A

Scale: Max

m

Exist. entrance_g_rade

Culvert
Min. Dio. 450mm
Min. cover 300mm
Min. length 10m

EARTH FILL

NOTE: All dimensions are in meters or millimeters unless otherwise specified.

DUFFERIN COUNTY

ENTRANCE

COMMERCIAL/INDUSTRIAL/INSTITUTIONAL

SEPTEMBER 1999

DC-04